

# PRODUCT DESCRIPTION

## optibelt **VB** CLASSIC V-BELTS

### DIN 2215 / ISO 4184

#### Structure/Properties

optibelt VB classic V-belts are manufactured using the same production processes as those for optibelt SK high performance wedge belts.

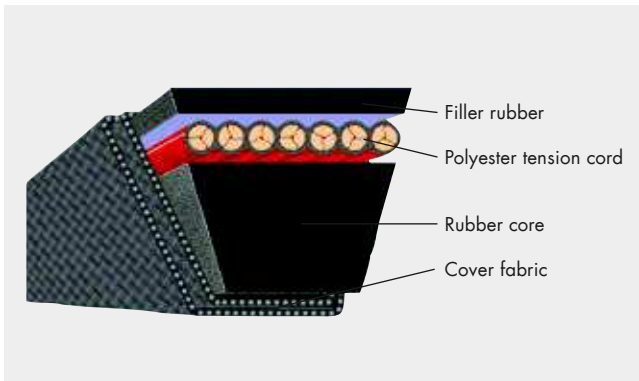

The components used are perfectly suited to the power ratings  $P_N$ . These values are far above those given by DIN 2218. Thus the operational safety in existing drives is increased and overloading is avoided.

- optibelt VB classic V-belts have a height-width ratio of 1:1.6.
- The maximum belt speed  $v_{max} = 30$  m/s should not be exceeded.
- The allowed flexibility rate is far below that of wedge belts. It is  $f_{B, max} = 80$  s<sup>-1</sup>.

#### Application areas

optibelt VB classic V-belts are mainly employed as replacement parts for industrial drives. For new drives, the use of high performance wedge belts is almost always recommended due to reasons of space and cost. However, special drives such as V-flat drives can often only be operated with classic V-belts. In special constructions, optibelt VB classic V-belts tackle difficult drives in the gardening sector and in agricultural machinery.

For these applications special belt constructions and calculation methods are required which are not included in this manual. In these cases we ask you to give us the according drive data.

#### Standardisation/Dimensions

optibelt VB classic V-belts in the profiles Y/6, Z/10, A/13, B/17, C/22, D/32 and E/40 are standardised according to DIN 2215 and ISO 4184.

Further, non-standardised ISO profiles 5, 8, 20 and 25 are available. These profiles should however not be used due to reasons of exchangeability and rationalisation.

**The ISO standard 4184 specifies the datum length for measuring the belt length. The former belt designation of the inside length  $L_i$  is replaced by the datum length  $L_d$ . For the conversion factors from pitch to inside length, please see page 161.**

**Note:** Electrically conductive according to ISO 1813.

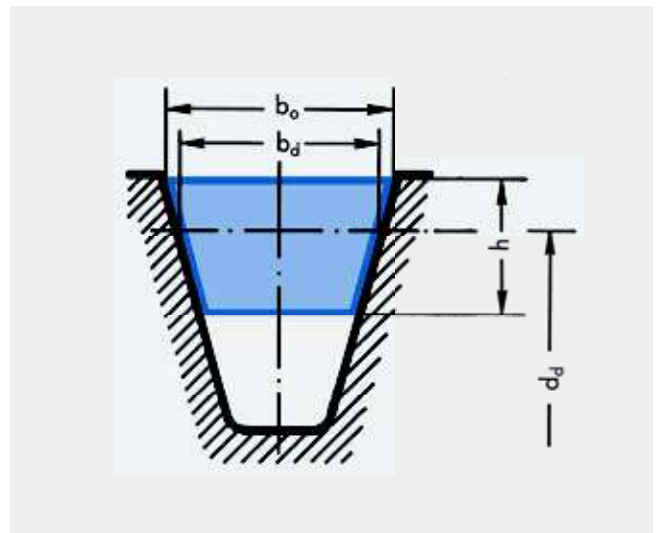

Table 7

Profile	DIN 2215	(5)	6	(8)	10	13	17	(20)	22	(25)	32	40
	ISO 4184	-	Y	-	Z	A	B	-	C	-	D	E
Belt top width	$b_o \approx$	5	6	8	10	13	17	20	22	25	32	40
Datum width	$b_d$	4.2	5.3	6.7	8.5	11	14	17	19	21	27	32
Belt height	$h \approx$	3	4	5	6	8	11	12.5	14	16	20	25
Recommended minimum pulley outside diameter	$d_{d, min}$	20	28	40	50	75	125	160	200	250	355	500
Belt weight (kg/m)	$\approx$	0.018	0.026	0.042	0.064	0.109	0.190	0.266	0.324	0.420	0.690	0.958
Flex rate (s <sup>-1</sup> )	$f_{B, max} \approx$						80					
Belt speed (m/s)	$v_{max} \approx$						30					

# STANDARD RANGE

## optibelt **VB** CLASSIC V-BELTS

### DIN 2215 / ISO 4184

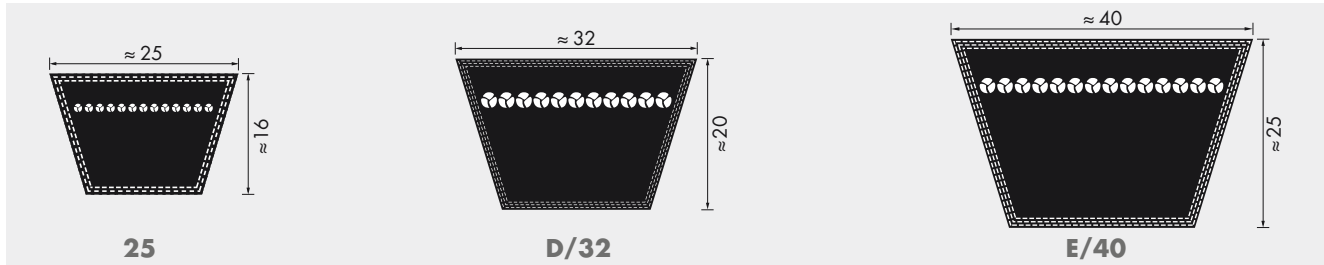

Profile 25		Profile D/32			Profile E/40		
Datum length ISO $L_d$ [mm]	Inside length $L_i$ [mm]	Belt no.	Datum length ISO $L_d$ [mm]	Inside length $L_i$ [mm]	Belt no.	Datum length ISO $L_d$ [mm]	Inside length $L_i$ [mm]
1460	1400	D 79	2075	2000	E 118	3080	3000
1560	1500	D 98	2575	2500	E 158	4080	4000
1660	1600	D 104	2725	2650	E 197	5080	5000
1760	1700	D 110	2875	2800	E 220	5680	5600
1860	1800	D 118	3075	3000	E 236	6080	6000
1960	1900	D 120	3123	3048	E 248	6380	6300
2060	2000	D 124	3225	3150	E 280	7180	7100
2180	2120	D 128	3326	3251	E 295	7580	7500
2300	2240	D 132	3425	3350	E 315	8080	8000
2420	2360	D 135	3500	3425	E 354	9080	9000
2560	2500	D 136	3529	3454	E 394	10080	10000
2710	2650	D 140	3625	3550	E 441	11280	11200
2760	2700	D 144	3733	3658	E 492	12580	12500
2860	2800	D 148	3825	3750			
3060	3000	D 154	4000	3925			
3210	3150	D 158	4075	4000			
3410	3350	D 162	4190	4115			
3610	3550	D 167	4325	4250			
3810	3750	D 173	4469	4394			
4060	4000	D 177	4575	4500			
4310	4250	D 180	4647	4572			
4560	4500	D 187	4825	4750			
4810	4750	D 195	5028	4953			
5060	5000	D 197	5075	5000			
5360	5300	D 208	5375	5300			
5660	5600	D 210	5409	5334			
6060	6000	D 220	5675	5600			
6360	6300	D 225	5790	5715			
6760	6700	D 236	6075	6000			
7160	7100	D 240	6171	6096			
7560	7500	D 248	6375	6300			
8060	8000	D 264	6775	6700			
8560	8500	D 270	6933	6858			
9060	9000	D 280	7175	7100			
		D 295	7575	7500			
		D 300	7695	7620			
		D 315	8075	8000			
		D 330	8457	8382			
		D 335	8575	8500			
		D 354	9075	9000			
		D 374	9575	9500			
		D 394	10075	10000			
		D 441	11275	11200			
Maximum standard production length: 21 000 mm $L_i$ Over 18 000 to 21 000 mm on request Minimum order quantity: Over 1800 mm = 14 pieces for non-standard length ranges 42 pieces for certain special constructions Weight: $\approx$ 0.420 kg/m		Maximum standard production length: 21 000 mm $L_i$ Over 18 000 to 21 000 mm on request Minimum order quantity: Over 2000 mm = 11 pieces for non-standard length ranges 33 pieces for certain special constructions Weight: $\approx$ 0.668 kg/m			Maximum production length: 21 000 mm $L_i$ Minimum order quantity: Over 3000 mm = 7 pieces for non-standard length ranges 21 pieces for certain special constructions Weight: $\approx$ 0.958 kg/m		
Datum length $L_d \triangleq$ Pitch length $L_w/L_p$ Further sizes on request							

Lengths in **bold** type are in S=C plus (SetConstant).