



SAPIT

flex®

GIUNTI DI TRASMISSIONE DI POTENZA

POWER TRANSMISSION COUPLINGS



GIUNTI RIGIDI
RIGID COUPLINGS

CERTIFICATE OF APPROVAL

This is to certify that the Quality Management System of:

SAPITFLEX S.r.l.
Via Lainate, 20
20010 Pogliano Milanese (Milano) – Italia

has been approved by Lloyd's Register Quality Assurance
to the following Quality Management System Standards:

ISO 9001

The Quality Management System is applicable to:

**Design and manufacture of transmission couplings. Design
and manufacture of gears. Provision of maintenance and
reinstatement services of couplings, gears and mechanical
equipments for metallurgical and mechanical industries.**

This certificate is valid only in association with the certificate schedule bearing the same number on
which the locations applicable to this approval are listed.

Approval Certificate
No: LRC 0160086/QMS/U/EN

Original Approval: 24th July 1996



Issued by: Lloyd's Register Quality Assurance Italy Srl
for and on behalf of Lloyd's Register Quality Assurance Limited



This document is subject to the provision below
Via Cadorna, 69 20090 Vimodrone (MI)

For and on behalf of Hiramford, Middlemarch Office Village, Siskin Drive, Coventry, CV3 4FJ, United Kingdom.

This approval is carried out in accordance with the LRQA assessment and certification procedures and monitored by LRQA.
The use of the UKAS Accreditation Mark indicates Accreditation in respect of those activities covered by the Accreditation Certificate Number 001

QUESTIONARIO PER LA SELEZIONE DEI GIUNTI
DETAILS FOR COUPLINGS SELECTION

Tipo di macchina motrice:

Type of driving machine:

POTENZA HP o KW:

Nominal rating transmissible HP or KW:

Velocità giri/1':

Speed RPM:

Diametro albero:

Shaft diameter:

Lunghezza albero:

Shaft length:

Tipo di macchina condotta:

Type of driven machine:

Diametro albero:

Shaft diameter:

Lunghezza albero:

Shaft length:

Distanza tra le teste albero motore e condotto:

Distance between DBSE and shaft:

Eventuali sovraccarichi:

Torque overload:

Tipo di montaggio (orizzontale/verticale):

Assembly type (horizontal/vertical):

Eventuali indicazioni per la finitura dei fori nei mozzi:

Additional information for finished bore of hubs:

Serie Ranges RMO

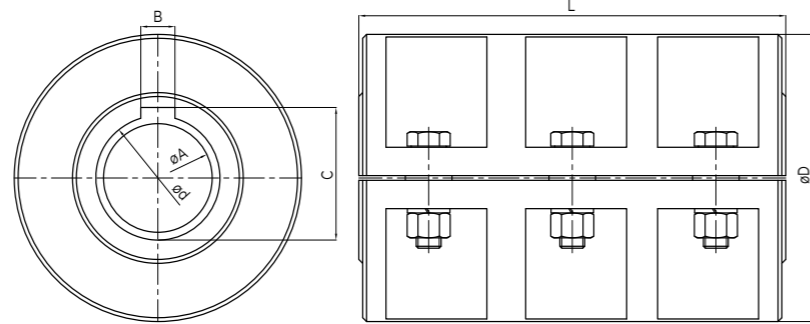

Caratteristiche Tecniche Technical Features

TIPO SIZE	POTENZA POWER		COPPIA TORQUE	VELOCITÀ MAX MAX SPEED	D	d	A	B	C	L	PESO WEIGHT	INERZIA MR ² INERTIA MR ²
	HP/n	KW/n										
25	0.006	0.004	40	2000	75	25	20	8	28.3	115	3	0.0004
30	0.010	0.007	70	1600	95	30	25	8	33.3	150	5	0.0089
35	0.014	0.010	100	1500	100	35	30	10	38.3	160	6	0.0118
40	0.021	0.016	150	1450	110	40	35	12	43.3	175	7	0.0210
45	0.043	0.031	300	1400	115	45	40	14	48.8	185	8.5	0.0223
50	0.064	0.047	450	1350	125	50	45	14	53.8	200	11	0.0319
60	0.128	0.094	900	1200	145	60	50	18	64.4	225	16	0.0552
70	0.256	0.188	1800	1150	165	70	60	20	74.9	250	22.5	0.1003
80	0.398	0.293	2800	1100	185	80	70	22	85.4	275	28	0.1536
90	0.598	0.439	4200	1000	205	90	80	25	95.4	300	40	0.2595
100	0.783	0.575	5500	950	255	100	90	28	106.4	325	73	0.5367
110	0.996	0.733	7000	950	260	110	100	28	116.4	390	90	0.8394
125	1.423	1.046	10000	900	280	125	110	32	132.4	430	115	1.2279
140	1.993	1.465	14000	850	310	140	125	36	148.4	460	157	2.0249
160	3.131	2.302	22000	750	360	160	140	40	169.4	560	246	4.1182
180	4.412	3.244	31000	700	400	180	160	40	190.4	630	365	7.6082

DIMENSIONI RIFERITE A MODELLI STANDARD
PESI E INERZIE Mr² SONO CALCOLATI CON FORO MINIMO A
MATERIALE GHISA GRIGIA EN-GJL-250 UNI EN 1561:1998

DATI E DIMENSIONI CONTENUTI IN QUESTO CATALOGO
POSSONO ESSERE VARIATI SENZA PREAVVISO

DIMENSIONS REFERRED TO STANDARD MODELS
WEIGHT AND INERTIA Mr² ARE CALCULATED WITH MINIMUM BORE A
MATERIAL CAST IRON EN-GJL-250 UNI EN 1561:1998

FIGURES AND DIMENSIONS IN THIS CATALOGUE
MAY CHANGE WITHOUT PRIOR NOTICE

Serie Ranges RFN

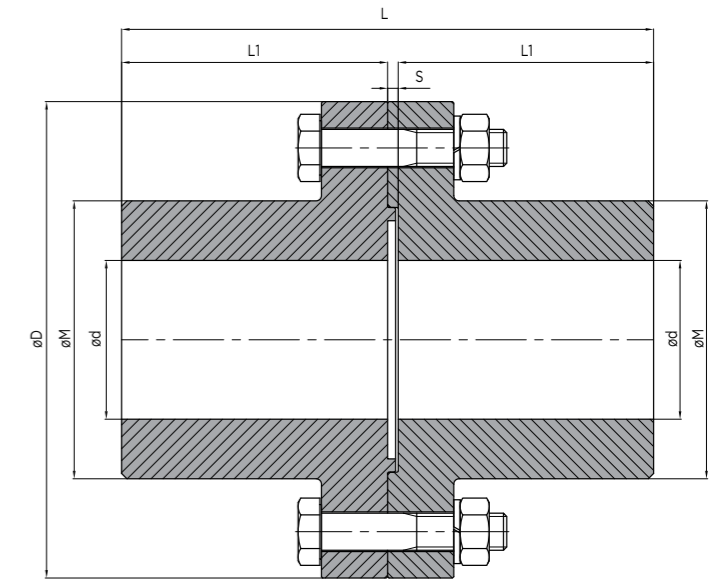

Caratteristiche Tecniche Technical Features

TIPO SIZE	POTENZA POWER		COPPIA TORQUE	VELOCITÀ MAX MAX SPEED	D	d max	L	L1	S	M	PESO WEIGHT	INERZIA MR ² INERTIA MR ²	C. di S.
	HP/n	KW/n											Nm
95-4-8	0.050	0.036	350	5000	95	40	83	40	3	60	2.5	0.0039	35
115-6-8	0.100	0.073	700	5000	115	55	113	55	3	80	5.3	0.115	35
135-6-10	0.185	0.136	1300	5000	135	65	133	65	3	92	8.5	0.0255	75
155-8-10	0.300	0.220	2100	4900	155	80	163	80	3	112	14	0.0571	75
175-8-12	0.500	0.366	3500	4350	175	90	184	90	4	126	21	0.1067	120
195-10-12	0.712	0.523	5000	3900	195	100	204	100	4	146	30	0.1940	120
215-8-16	1.067	0.785	7500	3550	215	110	224	110	4	154	39	0.3030	300
235-10-16	1.423	1.047	10000	3250	235	125	254	125	4	175	54	0.5150	300
255-12-16	1.992	1.466	14000	3000	255	140	284	140	4	195	74	0.8293	300
275-10-18	2.348	1.727	16500	2750	275	145	295	145	5	202	84	1.0683	430
295-12-18	3.060	2.251	21500	2600	295	155	315	155	5	220	105	1.5423	430
315-12-20	3.985	2.932	28000	2400	315	165	335	165	5	232	126	2.0959	600
335-16-20	5.694	4.188	40000	2250	335	180	365	180	5	252	159	3.0355	600
355-16-22	7.117	5.235	50000	2150	355	190	385	190	5	267	190	4.0940	800
375-18-22	9.040	6.650	63500	2000	375	205	415	205	5	287	233	5.6464	800
395-18-24	10.676	7.853	75000	1900	395	210	425	210	5	296	258	6.8771	1000
415-20-24	12.811	9.424	90000	1800	415	225	455	225	5	315	310	9.1865	1000

DIMENSIONI RIFERITE A MODELLI STANDARD
PESI E INERZIE Mr² SONO CALCOLATI CON FORO MAX
MATERIALE ACCIAIO

DATI E DIMENSIONI CONTENUTI IN QUESTO CATALOGO
POSSONO ESSERE VARIATI SENZA PREAVVISO

DIMENSIONI RIFERITE A MODELLI STANDARD
WEIGHT AND INERTIA Mr² ARE CALCULATED WITH MAX BORE
MATERIAL STEEL

FIGURES AND DIMENSIONS IN THIS CATALOGUE
MAY CHANGE WITHOUT PRIOR NOTICE



www.sapitflex.com

Via Lainate, 20 - 20010 Pogliano Milanese (MI) - Tel. +39 02 9396831 r.a. - Fax +39 02 93255163
info@sapitflex.com