

**Installation and Operation Manual TSCHAN®  
Flexible Coupling**

**Nor-Mex® LG, KG, MG**



---

## Table of Contents

| Chapter                                       | Page |
|---|------|
| 1 Notes on safety.....                        | 2    |
| 2 Technical Description .....                 | 3    |
| 2.1 Intended Application .....                | 3    |
| 3 Marking of the coupling.....                | 3    |
| 4 Storage .....                               | 4    |
| 5 Construction .....                          | 4    |
| 6 Technical Data.....                         | 5    |
| 7 Installation .....                          | 7    |
| 7.1 To be observed prior to installation..... | 7    |
| 7.2 Finish Bores.....                         | 7    |
| 7.3 Coupling installation .....               | 8    |
| 8 Coupling Alignment.....                     | 10   |
| 8.1 Angular misalignment $\Delta K_w$ .....   | 11   |
| 8.2 Radial misalignment $\Delta K_r$ .....    | 11   |
| 8.3 Axial misalignment.....                   | 12   |
| 9 Operation.....                              | 13   |
| 9.1 Check of direction of rotation .....      | 16   |
| 10 Maintenance .....                          | 18   |
| 10.1 Wear inspection on the buffer ring.....  | 18   |
| 10.2 Wear limit of the buffer ring .....      | 19   |
| 10.3 Replacement of the buffer ring .....     | 19   |
| 11 Waste Disposal .....                       | 20   |

---

### 1 Notes on safety

The present assembly and operating instruction (AOI) constitutes a part of the coupling supply. Always keep the AOI near the coupling well accessible.

The German version of this manual is the predominant and binding version.

Make sure that all persons charged with the assembly, operating, service, and maintenance have read and understood the AOI and follow all the points:

- Avert hazards for body and life of the user and third parties.
- Ensure the operating safety of the coupling.
- Avoid the loss of use and environmental impairment through false handling.

In the case of transport, mounting, dismounting and maintenance, attention is to be paid to the relevant regulations for industrial safety and for environmental care.

The coupling may only be operated, mounted, serviced and maintained by authorised and trained personnel.

The user must take into account that the bolting elements of coupling parts may be adversely affected by the heat produced by a brake disk/ brake drum due to the resultant friction. Make sure that the combination of the employed brake lining with the material of the brake disk/ brake drum does not lead to sparks or impermissible thermal growth. The brake disk is

normally made of steel, and the brake disk is normally made of cast iron with nodular graphite. In case of any doubt, please consult the supplier!

In the interest of further development, we reserve the right to make changes which serve technological progress.

By the use of accessories and spare parts, which were not originally manufactured by TSCHAN GmbH, we are not responsible for any resulting damage or liability or guarantee.

---

## 2 Technical Description

The NOR-Mex<sup>®</sup> LG, KG and MG couplings are torsionally flexible, puncture proof claw couplings.

They compensate for angular, radial and axial shaft misalignments within defined limits. The coupling transmits torque through elastic buffers loaded in compression. These buffers come in Perbunan (Pb), and are connected to each other to form an intermediate buffer ring.

The buffer ring dampens shocks and torsional vibrations. It is resistant to oil and electrically conductive.

One of the coupling halves consists of two parts which allows for the easy separation of the coupled machines. The direction of rotation can be checked after having retracted the claw ring. It is also possible to radially remove a coupling half. The buffer ring can be replaced without having to displace the machines.

The coupling is suitable for use in both directions of rotation and any installation position.

### 2.1 Intended Application

- The coupling must only be operated in normal industrial atmospheres. Since aggressive media may attack the coupling components, screws and elastic buffer rings, they represent a risk for the operational safety of the coupling. Consult TSCHAN GmbH in such cases.
- In order to ensure trouble-free and reliable operation, the coupling has to be sized according to the design specifications, e.g. according to DIN 740, part 2, (or acc. to catalog NorMex<sup>®</sup>), with a service factor appropriate for the service conditions.
- Except for the production of a finish bore with keyway (see 7.2 'Finish Bores'), no further modifications are allowed to be carried out on the coupling.
- The coupling shall only be used and operated within the frame of the conditions as defined in the performance or delivery contract.
- Any change in the operation conditions or service parameters requires the verification of the coupling design.

---

## 3 Marking of the coupling

The product line NOR-Mex<sup>®</sup> has its hardness in Shore (A) indicated on the elastic intermediate ring.

## 4 Storage

On receipt of the goods, the supply is to be checked immediately for completeness and correctness. Possible damages incurred during transit and / or missing parts are to be notified in writing.

The coupling parts can be stored in their delivered standard-state for 6 months in a dry, roofed place at normal room temperature. For a longer storage duration a long-term preservation is necessary (consult TSCHAN GmbH). The elastic intermediate ring must not be subjected to ozone containing mediums, direct solar influence or strong light sources with ultraviolet-light. The relative humidity must not exceed 65%. In the case of proper storage the characteristics of the elastic intermediate ring remain unchanged for almost up to three years.

## 5 Construction

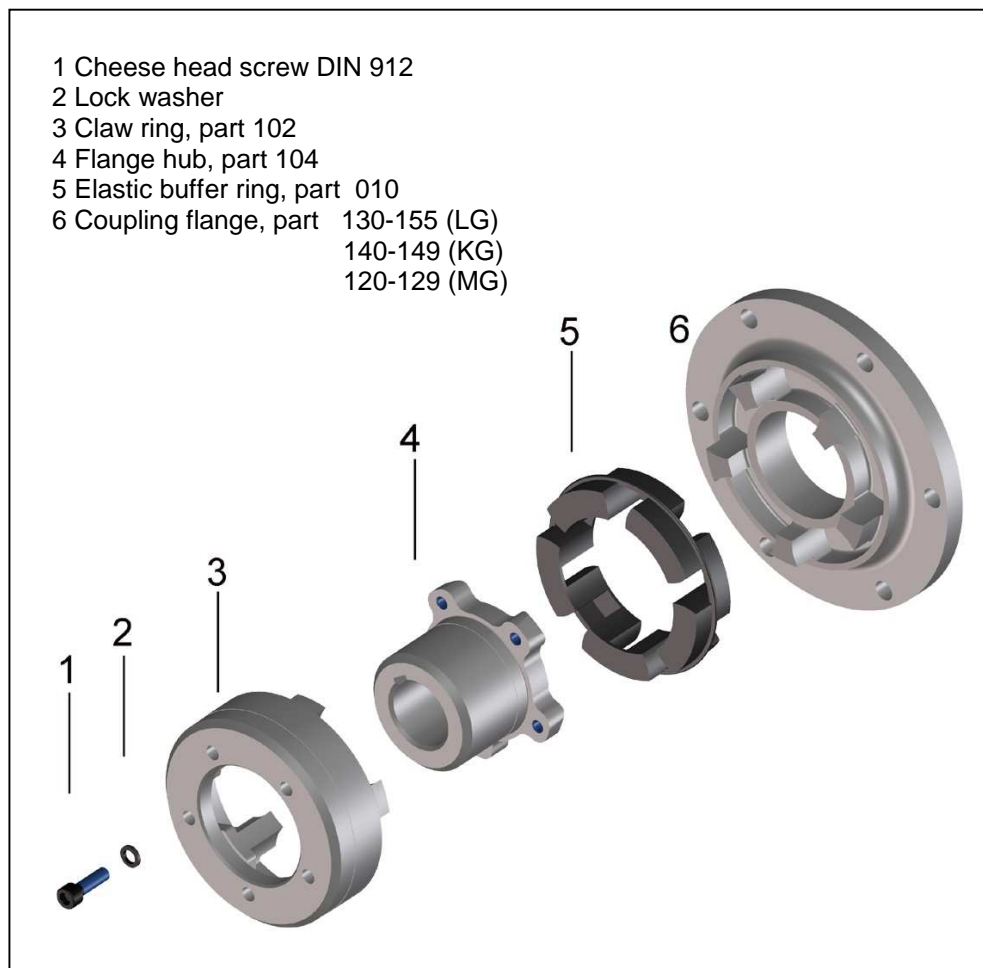

Fig. 1 Construction **Nor-Mex**<sup>®</sup> LG, KG, MG

**Note:**

The claw ring (part 3) and the flange hub (part 4) arrive bolted to each other. Balanced parts are match-marked to each other.

## 6 Technical Data

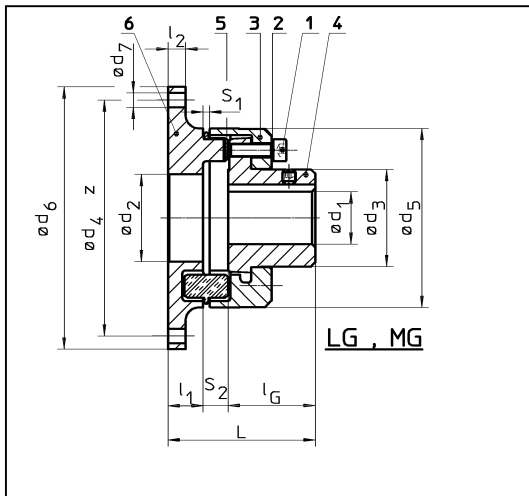

Fig. 2 Nor-Mex® LG, MG

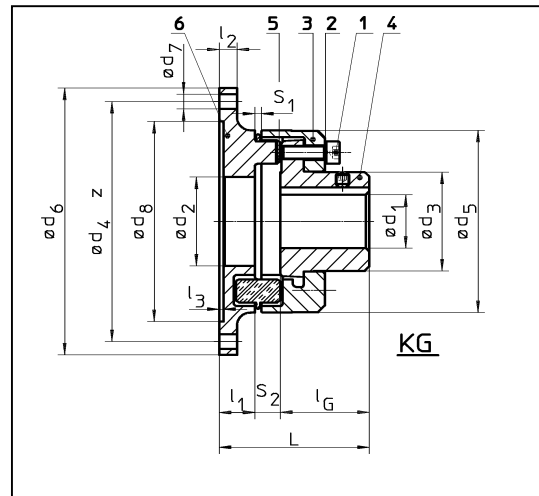

Fig. 3 Nor-Mex® KG

Table 1 Technical Data:

| Size<br>Nor-Mex<br>LG KG MG | T <sub>Knom.</sub><br>Pb72<br>[Nm] | T <sub>Kmax</sub><br>Pb72<br>[Nm] | T <sub>Knom.</sub><br>Pb82<br>[Nm] | T <sub>Kmax</sub><br>Pb82<br>[Nm] | n <sub>max</sub><br>[rpm] |
|-----------------------------|------------------------------------|-----------------------------------|------------------------------------|-----------------------------------|---------------------------|
| 82                          | 48                                 | 100                               | 75                                 | 150                               | 8000                      |
| 97                          | 96                                 | 200                               | 150                                | 210                               | 7000                      |
| 112                         | 150                                | 310                               | 230                                | 540                               | 6000                      |
| 128                         | 250                                | 500                               | 380                                | 650                               | 5000                      |
| 148                         | 390                                | 800                               | 600                                | 1350                              | 4500                      |
| 168                         | 630                                | 1300                              | 980                                | 1800                              | 4000                      |
| 194                         | 1050                               | 2000                              | 1650                               | 2400                              | 3500                      |
| 214                         | 1500                               | 3100                              | 2400                               | 4200                              | 3000                      |
| 240                         | 2400                               | 4800                              | 3700                               | 6200                              | 2750                      |
| 265                         | 3700                               | 7500                              | 5800                               | 8300                              | 2500                      |
| 295                         | 4900                               | 10000                             | 7550                               | 10500                             | 2250                      |
| 330                         | 6400                               | 13000                             | 9900                               | 14500                             | 2000                      |
| 370                         | 8900                               | 18200                             | 14000                              | 20000                             | 1750                      |
| 415                         | 13200                              | 27000                             | 20500                              | 27000                             | 1500                      |
| 480                         | 18000                              | 36000                             | 28000                              | 66000                             | 1400                      |
| 575                         | 27000                              | 54000                             | 41000                              | 97500                             | 1200                      |

Table 2 Technical Data Nor-Mex® LG:

| Size<br>Nor-Mex<br>LG | d <sub>1</sub><br>max<br>[mm] | d <sub>2</sub><br>[mm] | d <sub>3</sub><br>[mm] | d <sub>4</sub><br>[mm] | d <sub>5</sub><br>[mm] | d <sub>6</sub><br>h8<br>[mm] | d <sub>7</sub><br>[mm] | z<br>num-<br>ber | l <sub>1</sub><br>[mm] | l <sub>2</sub><br>[mm] | l <sub>G</sub><br>[mm] | L<br>[mm] | S <sub>1</sub><br>[mm] | S <sub>2</sub><br>[mm] | m<br>not bored<br>[kg] |
|-----------------------|-------------------------------|------------------------|------------------------|------------------------|------------------------|------------------------------|------------------------|------------------|------------------------|------------------------|------------------------|-----------|------------------------|------------------------|------------------------|
| 82-120                | 32                            | 40                     | 44,5                   | 108                    | 82                     | 120                          | 6,6                    | 6                | 16                     | 8                      | 40                     | 68        | 3,0                    | 12                     | 1,8                    |
| 97-144                | 39                            | 50                     | 54,5                   | 128                    | 97                     | 144                          | 9,0                    | 6                | 20                     | 10                     | 49                     | 83        | 3,0                    | 14                     | 2,9                    |
| 112-158               | 46                            | 60                     | 64,5                   | 142                    | 112                    | 158                          | 9,0                    | 6                | 22                     | 10                     | 58                     | 95        | 3,5                    | 15                     | 4,4                    |
| 128-180               | 53                            | 70                     | 74,5                   | 160                    | 128                    | 180                          | 11,0                   | 6                | 25                     | 13                     | 68                     | 109       | 3,5                    | 16                     | 6,7                    |
| 148-200               | 65                            | 90                     | 92,5                   | 180                    | 148                    | 200                          | 11,0                   | 7                | 28                     | 13                     | 78                     | 124       | 3,5                    | 18                     | 9,8                    |
| 168-220               | 75                            | 100                    | 104,5                  | 200                    | 168                    | 220                          | 11,0                   | 8                | 34                     | 13                     | 87                     | 142       | 3,5                    | 21                     | 14,0                   |
| 194-248               | 85                            | 115                    | 121,5                  | 224                    | 194                    | 248                          | 13,5                   | 8                | 38                     | 16                     | 97                     | 159       | 3,5                    | 24                     | 21,0                   |
| 214-274               | 95                            | 130                    | 135,5                  | 250                    | 214                    | 274                          | 13,5                   | 8                | 42                     | 16                     | 107                    | 175       | 4,0                    | 26                     | 27,9                   |
| 240-314               | 100                           | 145                    | 146,0                  | 282                    | 240                    | 314                          | 17,5                   | 8                | 45                     | 20                     | 117                    | 192       | 4,0                    | 30                     | 37,6                   |
| 265-344               | 115                           | 160                    | 164,0                  | 312                    | 265                    | 344                          | 17,5                   | 8                | 50                     | 20                     | 137                    | 220       | 5,5                    | 33                     | 53,4                   |
| 295-380               | 130                           | 170                    | 181,0                  | 348                    | 295                    | 380                          | 17,5                   | 9                | 52                     | 22                     | 147                    | 236       | 8,0                    | 37                     | 70,2                   |
| 330-430               | 135                           | 200                    | 208,0                  | 390                    | 330                    | 430                          | 22,0                   | 9                | 56                     | 25                     | 156                    | 252       | 8,0                    | 40                     | 91,7                   |
| 370-480               | 160                           | 235                    | 241,0                  | 440                    | 370                    | 480                          | 22,0                   | 10               | 62                     | 25                     | 176                    | 281       | 8,0                    | 43                     | 126,0                  |
| 415-575               | 180                           | 270                    | 275,0                  | 528                    | 415                    | 575                          | 26,0                   | 10               | 65                     | 30                     | 196                    | 306       | 8,0                    | 45                     | 183,9                  |
| 480-615               | 190                           | 320                    | 289,0                  | 568                    | 480                    | 615                          | 26,0                   | 10               | 65                     | 30                     | 220                    | 330       | 8,0                    | 45                     | 244,7                  |
| 575-692               | 260                           | 400                    | 368                    | 645                    | 575                    | 692                          | 26,0                   | 10               | 65                     | 30                     | 240                    | 350       | 8,0                    | 45                     | 370,1                  |

**Table 3 Technical Data Nor-Mex® KG:**

| Size Nor-Mex KG | d <sub>1</sub> max [mm] | d <sub>2</sub> [mm] | d <sub>3</sub> [mm] | d <sub>4</sub> [mm] | d <sub>5</sub> [mm] | d <sub>6</sub> [mm] | d <sub>7</sub> [mm] | z number | d <sub>8</sub> H7 [mm] | l <sub>1</sub> [mm] | l <sub>2</sub> [mm] | l <sub>3</sub> [mm] | l <sub>G</sub> [mm] | L [mm] | S <sub>1</sub> [mm] | S <sub>2</sub> [mm] | m not bored [kg] |
|-----------------|-------------------------|---------------------|---------------------|---------------------|---------------------|---------------------|---------------------|----------|------------------------|---------------------|---------------------|---------------------|---------------------|--------|---------------------|---------------------|------------------|
| 168-254         | 75                      | 99,5                | 104,5               | 228                 | 168                 | 254                 | 13,5                | 8        | 195                    | 34                  | 13                  | 3,5                 | 87                  | 142    | 3,5                 | 21                  | 14,6             |
| 194-290         | 85                      | 114,5               | 121,5               | 265                 | 194                 | 290                 | 13,5                | 8        | 220                    | 38                  | 16                  | 4,0                 | 97                  | 159    | 3,5                 | 24                  | 22,1             |
| 214-334         | 95                      | 129,5               | 135,5               | 310                 | 214                 | 334                 | 13,5                | 12       | 265                    | 42                  | 16                  | 3,5                 | 107                 | 175    | 4,0                 | 26                  | 30,1             |
| 240-390         | 100                     | 144,5               | 146,0               | 360                 | 240                 | 390                 | 13,5                | 16       | 315                    | 45                  | 20                  | 3,5                 | 117                 | 192    | 4,0                 | 30                  | 42,0             |
| 265-470         | 115                     | 159,5               | 164,0               | 420                 | 265                 | 470                 | 17,5                | 16       | 360                    | 50                  | 20                  | 3,5                 | 137                 | 220    | 5,5                 | 33                  | 62,7             |

**Table 4 Technical Data Nor-Mex® MG:**

| Size Nor-Mex MG | d <sub>1</sub> max [mm] | d <sub>2</sub> [mm] | d <sub>3</sub> [mm] | d <sub>4</sub> [mm] | d <sub>5</sub> [mm] | d <sub>6</sub> f7 [mm] | d <sub>7</sub> [mm] | z number | l <sub>1</sub> [mm] | l <sub>2</sub> [mm] | l <sub>G</sub> [mm] | L [mm] | S <sub>1</sub> [mm] | S <sub>2</sub> [mm] | m not bored [kg] |        |
|-----------------|-------------------------|---------------------|---------------------|---------------------|---------------------|------------------------|---------------------|----------|---------------------|---------------------|---------------------|--------|---------------------|---------------------|------------------|--------|
| 97-6,5"         | 39                      | 49,5                | 54,5                | 200,02              | 97                  | 215,90                 | 9,5                 | 6        | 20                  | 10                  | 49                  | 73,0   | 3,0                 | 14                  | 6,0              |        |
| 112-6,5"        | 46                      | 59,5                | 64,5                | 200,02              | 112                 | 215,90                 | 9,5                 | 6        | 22                  | 10                  | 58                  | 85,5   | 3,5                 | 15                  | 7,2              |        |
| 112-7,5"        |                         |                     |                     | 222,25              |                     | 241,30                 |                     | 8        |                     |                     |                     |        |                     |                     | 6,2              |        |
| 128-7,5"        | 53                      | 69,5                | 74,5                | 222,25              | 128                 | 241,30                 | 9,5                 | 8        | 25                  | 13                  | 68                  | 98,5   | 3,5                 | 16                  | 8,5              |        |
| 128-8"          |                         |                     |                     | 244,47              |                     | 263,52                 |                     | 6        |                     |                     |                     |        |                     |                     | 9,3              |        |
| 128-10"         |                         |                     |                     | 295,27              |                     | 314,32                 |                     | 8        |                     |                     |                     |        |                     |                     | 11,2             |        |
| 148-8"          | 65                      | 89,5                | 92,5                | 244,47              | 148                 | 263,52                 | 11,0                | 6        | 28                  | 13                  | 78                  | 111,5  | 3,5                 | 18                  | 11,9             |        |
| 148-10"         |                         |                     |                     | 295,27              |                     | 314,32                 |                     | 8        |                     |                     |                     |        |                     |                     | 13,9             |        |
| 168-10"         | 75                      | 99,5                | 104,5               | 295,27              | 168                 | 314,32                 | 11,0                | 8        | 34                  | 13                  | 87                  | 127,5  | 3,5                 | 21                  | 17,7             |        |
| 168-11,5"       |                         |                     |                     | 333,37              |                     | 352,42                 |                     | 8        |                     |                     |                     |        |                     |                     | 19,4             |        |
| 194-11,5"       | 85                      | 114,5               | 121,5               | 333,37              | 194                 | 352,42                 | 11,0                | 8        | 38                  | 16                  | 97                  | 141,5  | 3,5                 | 24                  | 26,5             |        |
| 194-14"         |                         |                     |                     | 438,15              |                     | 466,72                 |                     | 14,5     |                     |                     |                     |        |                     |                     | 34,8             |        |
| 214-11,5"       | 95                      | 129,5               | 135,5               | 333,37              | 214                 | 352,42                 | 11,0                | 8        | 42                  | 16                  | 107                 | 156,0  | 4,0                 | 26                  | 32,3             |        |
| 214-14"         |                         |                     |                     | 438,15              |                     | 466,72                 |                     | 14,5     |                     |                     |                     |        |                     |                     | 40,5             |        |
| 240-11,5"       | 100                     | 144,5               | 146,0               | 333,37              | 240                 | 352,42                 | 11,0                | 8        | 45                  | 20                  | 117                 | 169,0  | 4,0                 | 30                  | 45,0             |        |
| 240-14"         |                         |                     |                     | 438,15              |                     | 466,72                 |                     |          |                     |                     |                     |        |                     |                     | 14,5             | 50,0   |
| 240-16"         |                         |                     |                     | 489,00              |                     | 517,52                 |                     |          |                     |                     |                     |        |                     |                     | 14,5             | 55,8   |
| 265-11,5"       | 115                     | 159,5               | 164,0               | 333,37              | 265                 | 352,42                 | 11,0                | 8        | 50                  | 20                  | 137                 | 195,5  | 5,5                 | 30                  | 59,1             |        |
| 265-14"         |                         |                     |                     | 438,15              |                     | 466,72                 |                     |          |                     |                     |                     |        |                     |                     | 14,5             | 64,4   |
| 265-16"         |                         |                     |                     | 489,00              |                     | 517,52                 |                     |          |                     |                     |                     |        |                     |                     | 14,5             | 70,1   |
| 265-18"         |                         |                     |                     | 542,92              |                     | 571,50                 |                     |          |                     |                     |                     |        |                     |                     | 18,0             | 76,1   |
| 295-14"         | 130                     | 169,5               | 181,0               | 438,15              | 295                 | 466,72                 | 14,5                | 8        | 52                  | 22                  | 147                 | 210,0  | 8,0                 | 37                  | 78,1             |        |
| 295-16"         |                         |                     |                     | 489,00              |                     | 517,52                 |                     |          |                     |                     |                     |        |                     |                     | 14,5             | 84,4   |
| 295-18"         |                         |                     |                     | 542,92              |                     | 571,50                 |                     |          |                     |                     |                     |        |                     |                     | 18,0             | 87,9   |
| 295-21"         |                         |                     |                     | 641,40              |                     | 673,10                 |                     |          |                     |                     |                     |        |                     |                     | 22,0             | 91,7   |
| 330-18"         |                         |                     |                     | 135                 |                     | 199,5                  |                     |          |                     |                     |                     |        |                     |                     | 208,0            | 542,92 |
| 330-21"         | 641,40                  | 673,10              | 12                  |                     | 131,1               |                        |                     |          |                     |                     |                     |        |                     |                     |                  |        |
| 330-24"         | 692,20                  | 733,40              | 22,0                |                     | 140,3               |                        |                     |          |                     |                     |                     |        |                     |                     |                  |        |
| 370-18"         | 160                     | 234,5               | 241,0               | 542,92              | 370                 | 571,50                 | 18,0                | 6        | 62                  | 25                  | 176                 | 250,0  | 8,0                 | 43                  | 139,1            |        |
| 370-21"         |                         |                     |                     | 641,40              |                     | 673,10                 |                     | 12       |                     |                     |                     |        |                     |                     | 160,7            |        |
| 370-24"         |                         |                     |                     | 692,20              |                     | 733,40                 |                     | 22,0     |                     |                     |                     |        |                     |                     | 176,7            |        |
| 415-18"         |                         |                     |                     | 180                 |                     | 269,5                  |                     | 275,0    |                     |                     |                     |        |                     |                     | 542,92           | 415    |
| 415-21"         | 641,40                  | 673,10              | 12                  |                     | 204,3               |                        |                     |          |                     |                     |                     |        |                     |                     |                  |        |
| 415-24"         | 692,20                  | 733,40              | 22,0                |                     | 220,5               |                        |                     |          |                     |                     |                     |        |                     |                     |                  |        |

The torques  $T_{Knom}$  and  $T_{Kmax}$  are valid for:

- buffer rings made from Perbunan Pb72 or Pb82,
- ambient temperatures of -40°C up to + 60°C,
- operation within the range of the specified alignment values.

For determining the size of the coupling according to DIN 740, part 2, (or to catalog NorMex®) various factors have to be taken into account:

- the temperature factor  $S_V$  in case of higher temperatures,
- the start-up factor  $S_z$  depending on the frequency of starts,
- the shock factor  $S_A, S_L$  depending on the service conditions.

For circumferential speeds above 22 m/s, we recommend to balance the coupling.

## 7 Installation

### 7.1 To be observed prior to installation



- **Danger of injuries!**
  - **Disconnect the drive before carrying out any work on the coupling!**
  - **Secure the drive against unintentional re-start and rotation!**
  - **Incorrectly tightened bolts can cause serious personal injuries and property damage!**
  - **In compliance with accident prevention regulations, you are obliged to protect all freely rotating parts by means of permanently installed guards/ covers against unintentional contact and falling objects.**
  - **To avoid sparks, covers made of stainless steel must be used!**
  - **As a minimum, the covers have to fulfill the requirements of protection type IP2X.**
  - **The covers must be designed to prevent dust from depositing on the coupling.**
  - **The cover must not contact the coupling nor impair the function of the coupling.**
- 
- Make sure that the speeds, torques and ambient temperatures as stated in chapter 6 'Technical Data' are not exceeded.
  - The maximum permissible bore diameters must not be exceeded.
  - Check whether the shaft-hub connections safely transmit the occurring operating torques.
  - The standard tolerance of TSCHAN for finish bores is fit H7.
  - Standard keyways comply with DIN 6885, sheet 1.
  - Check the dimensions and tolerances of shafts, hub bores, keys and keyways.
  - Set screws as required.

### 7.2 Finish Bores

The following procedure has to be observed to produce a finish bore in a coupling hub:

- Clean and remove all preservatives from the coupling hub.
- Mount the coupling hub between the surfaces marked with  $\lrcorner$  and carefully align the coupling hub.
- The values for  $\varnothing_{1\max}$  listed in table 2, 3 and 4 are valid for keyed connections according to DIN 6885/1 and must not be exceeded.
- Select the bore fit so that an interference fit such as H7/m6 results when mating it with the shaft tolerance.
- Axially lock the hub, for example by means of a setscrew on the back of the hub above the keyway

Contact TSCHAN GmbH if other shaft-hub connections are used.



- The stated maximum bore diameters are valid for keyed connections according to DIN 6885/1 and must not be exceeded.
- If these values are exceeded, the coupling can break.
- Flying coupling debris are a danger to life!

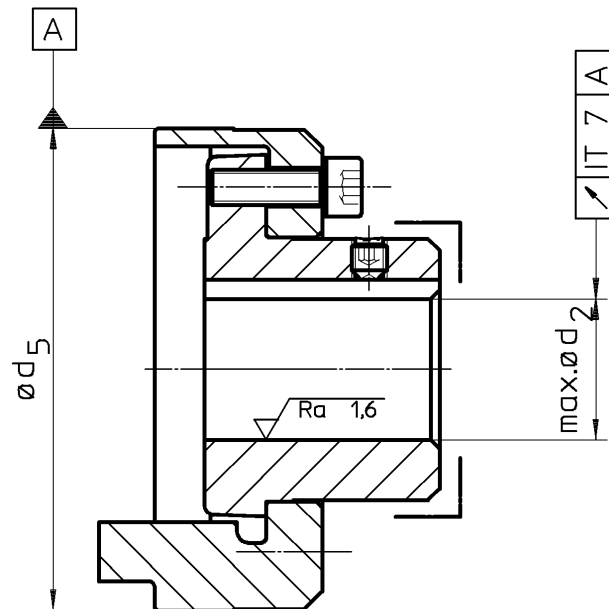

### 7.3 Coupling installation

- Remove the elastic buffer ring (Fig. 4, pos. 1).
- Prior to installation, carefully clean the bore of the flange hub and the shaft end. The surfaces must be clean, dry and free of grease.
- For larger couplings use suitable mounting tools and hoisting devices such as cranes or pulley blocks.
- Mount the coupling hub in the proper position on the shaft end (Fig. 4, pos. 2).

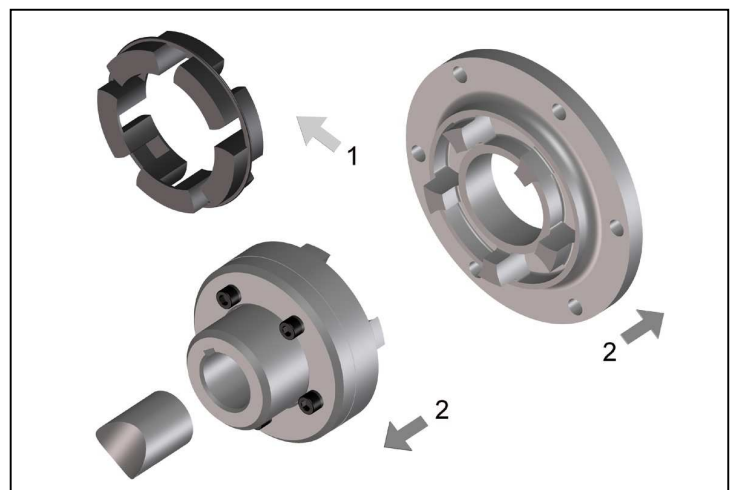

Fig. 4

**Note:**

To facilitate mounting, the hub can be heated to 80°C to 120°C. Take care for uniform heating.





- **Warning!**
- **Always wear heat-resistant gloves to protect yourself against injuries due to hot coupling components!**

- Mount the hub in such a manner that the shaft end is flush with the inner bore opening (Fig. 5). Observe other mounting procedures that may have been agreed upon in that regard!
- When tightening setscrews, secure them with an adhesive, such as e.g. Loctite 222, to prevent the screws from working loose or dropping out.
- Mount the coupling flange to the flange connection. Take care that the parts do not become canted at the centering seat (Fig. 4, pos. 2).

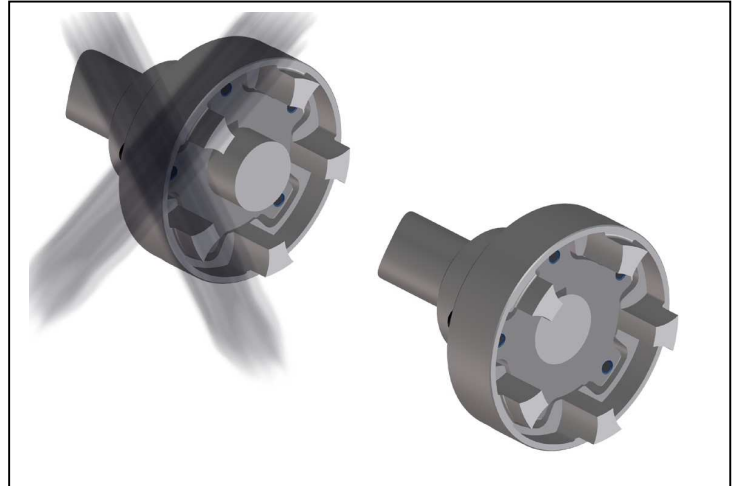

Fig. 5

**ATTENTION!**

The contact surfaces of the coupling flange and flange connection must be clean, dry and free of grease. Balanced parts are match-marked to each other.

**ATTENTION!**

Let the hot hub cool down to ambient temperature, before inserting the buffer ring.

- To facilitate mounting, the buffer ring can be coated with a sliding substance (e.g. talcum).
- Install the buffer ring in one of the coupling halves.
- Push together the shaft end with the mounted coupling half and the coupling flange (Fig. 6).
- Align the coupling in accordance with the instructions given in chapter 8 'Coupling Alignment'.

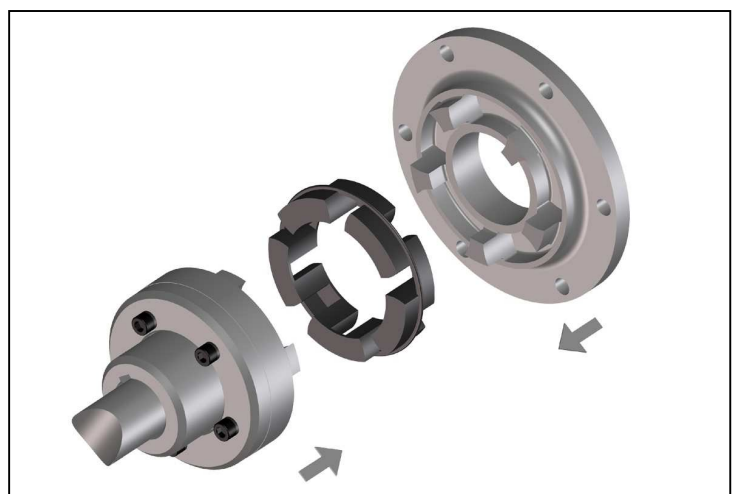

Fig. 6

## 8 Coupling Alignment



- **Danger of injuries!**
  - **Disconnect the drive before carrying out any work on the coupling.**
  - **Secure the drive against unintentional re-start and rotating!**
  - **Note:**
  - **Precise alignment of the coupling increases the lifetime of the intermediate buffer ring.**
  - **It is of utmost importance to observe the recommended alignment values. Exceeding the permissible misalignment values results in coupling damages and failures!**
- When aligning the cold equipment, take into account the expected thermal growth of the components, so that the permissible misalignment values for the coupling are not exceeded in operation.
  - Be aware that the coupling under misalignment imposes restoring forces on the adjacent shafts and bearings. Take into account that the larger the misalignment, the greater the restoring forces will be.
  - The maximum permissible misalignments stated in tables 5 to 7 are guiding values. We recommend not to fully utilize these values when aligning the coupling, so as to have sufficient reserves for thermal growth, foundation settlements etc. during operation.
  - In special applications with high demands on quiet running characteristics or higher speeds, alignment accuracies of  $\leq 0.1$  mm may be necessary for the three alignment levels.
  - If the coupling is mounted in a closed housing/ guard, so that alignment is no longer possible at a later point of time, make sure that the geometry and the fitting accuracy of the contact surfaces ensure true alignment of the shafts within the specified tolerances during operation.

### 8.1 Angular misalignment $\Delta K_w$

- Measure one complete revolution (360°) on the face of the outer diameter. Determine the largest deviation  $\Delta K_{w1}$  and the smallest deviation  $\Delta K_{w2}$  (Fig. 7).
- Calculate the angular misalignment:  $\Delta K_w = \Delta K_{w1} - \Delta K_{w2}$
- The values of table 5 are valid for a reference speed of 1500 rpm.

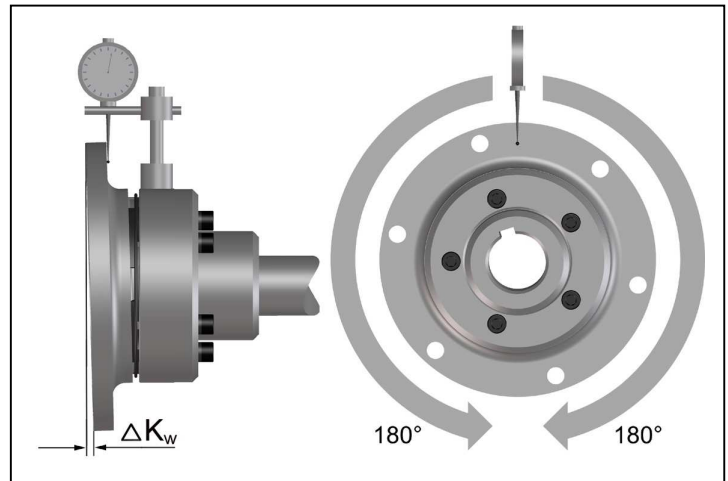

Fig. 7

**Table 5 Maximum permissible angular misalignment values:**

| Size                     | 82  | 97  | 112 | 128 | 148 | 168 | 194 | 214 | 240 | 265 | 295 | 330 | 370 | 415 | 480 | 575 |
|--------------------------|-----|-----|-----|-----|-----|-----|-----|-----|-----|-----|-----|-----|-----|-----|-----|-----|
| $\Delta K_{w \max}$ [mm] | 0,2 | 0,2 | 0,3 | 0,3 | 0,3 | 0,3 | 0,3 | 0,3 | 0,3 | 0,3 | 0,3 | 0,3 | 0,3 | 0,3 | 0,3 | 0,3 |

### 8.2 Radial misalignment $\Delta K_r$

- Measure one complete revolution (360°) on the face of the outer diameter. Determine the largest deviation  $\Delta K_{r1}$  and the smallest deviation  $\Delta K_{r2}$  (Fig. 8).
- Calculate the radial misalignment  $\Delta K_r = 0.5 \times (\Delta K_{r1} - \Delta K_{r2})$ . Observe the preceding sign of the measured values.
- The values of table 6 are valid for a reference speed of 1500 rpm.

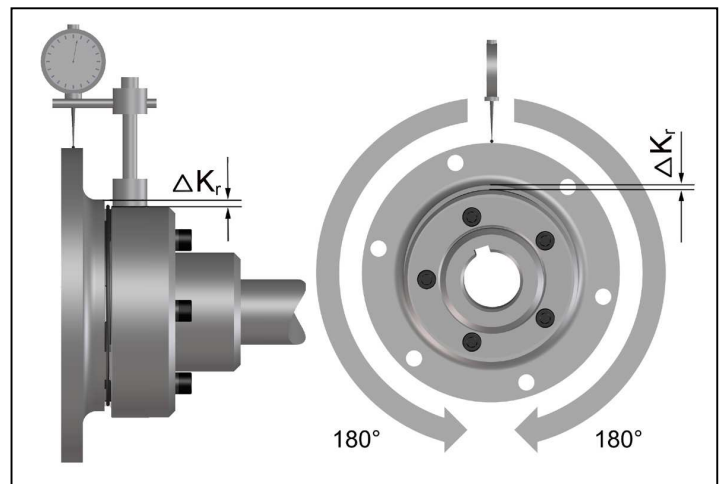

Fig. 8

**Table 6 Maximal permissible radial misalignment values:**

| Size                     | 82  | 97  | 112 | 128 | 148 | 168 | 194 | 214 | 240 | 265 | 295 | 330 | 370 | 415 | 480 | 575 |
|--------------------------|-----|-----|-----|-----|-----|-----|-----|-----|-----|-----|-----|-----|-----|-----|-----|-----|
| $\Delta K_{r \max}$ [mm] | 0,2 | 0,2 | 0,3 | 0,3 | 0,3 | 0,3 | 0,3 | 0,3 | 0,3 | 0,3 | 0,3 | 0,3 | 0,3 | 0,3 | 0,3 | 0,3 |

### 8.3 Axial misalignment

- Measure the axial gap dimension as shown in Fig. 9.
- During alignment, observe the gap dimension S and the maximum permissible tolerance X according to table 7.

**ATTENTION!**  
**Contact TSCHAN GmbH if larger axial misalignments are expected to occur during operation.**

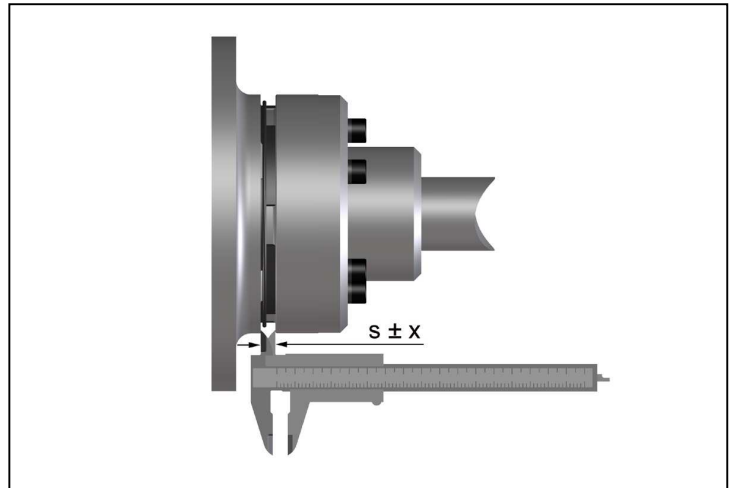

Fig. 9

**Table 7 Recommended axial misalignment values:**

| Size   | 82 | 97 | 112 | 128 | 148 | 168  | 194  | 214 | 240 | 265  | 295  | 330  | 370  | 415  | 480  | 575  |
|--------|----|----|-----|-----|-----|------|------|-----|-----|------|------|------|------|------|------|------|
| S [mm] | 3  | 3  | 3,5 | 3,5 | 3,5 | 3,5  | 3,5  | 4   | 4   | 5,5  | 8    | 8    | 8    | 8    | 8    | 8    |
| X [mm] | ±1 | ±1 | ±1  | ±1  | ±1  | ±1,5 | ±1,5 | ±2  | ±2  | ±2,5 | ±2,5 | ±2,5 | ±2,5 | ±2,5 | ±2,5 | ±2,5 |

## 9 Operation

When operating the coupling, its specific technical data has to be carefully observed (see chapter 6 'Technical Data'). These values must never be exceeded without the prior written approval by TSCHAN GmbH.

In order to ensure trouble-free and reliable performance of the coupling, the coupling has to be designed according to the selection specifications, e.g. according to DIN 740, part 2 (or acc. to catalog NOR-MEX<sup>®</sup>) with a service factor appropriate to the service conditions. Any change in the service conditions or service parameters always necessitates the verification of the coupling design.



- **Danger of injuries!**
- **Disconnect the drive before carrying out any work on the coupling!**
- **Secure the drive against unintentional re-start and rotation!**
- **Improperly tightened screws may cause parts to become flying projectiles and lead to most serious personal injuries and property damage!**
- **Before putting the coupling into operation, check the alignment and all screwed connections for correct tightening torque and firm fit!**
- **Before starting up the equipment, install all protective guards or covers in order to avoid contact with freely moving or rotating parts.**
- **To avoid sparks, covers made of stainless steel must be used!**
- **The covers have to comply with protection type IP2X as a minimum.**
- **The covers must be designed to prevent dust from depositing on the coupling parts.**
- **The covers must not contact the coupling nor impair its function.**

**When operating the coupling, pay attention to:**

- Changes in operating noises
- Vibrations

**Attention!**

- **Should you observe any unusual phenomena or problems when starting or operating the coupling, disconnect the driving equipment immediately!**
- Identify the cause for the problem using table 8 below "Operation Faults and Possible Causes" and correct the fault.  
The listed problems are some examples to assist you in troubleshooting.
- **All the machinery components and operation modes have to be considered for the determination and correction of mechanical problems!**

**Table 8 Operation Faults and Possible Causes:**

| <b>Trouble</b>                          | <b>Cause</b>                     | <b>Risk Warning</b>  | <b>Correction</b>  |
|---|----------------------------------|--|--|
| Irregular running noises/<br>vibrations | Alignment fault                  | Considerable increase of coupling temperature. Premature wear of elastic buffers. Increased reaction forces act on connected machines. | <ul style="list-style-type: none"> <li>- Disconnect drive</li> <li>- Remove cause for alignment fault</li> <li>- Re-align coupling</li> <li>- Inspect elastic buffers for wear</li> </ul>  |
|   | Elastic buffers worn out         | Coupling claws strike against each other. Spark formation, claw fracture, increased reaction forces.                                   | <ul style="list-style-type: none"> <li>- Disconnect drive</li> <li>- Check coupling components for damages and replace parts, if necessary</li> <li>- Replace elastic buffers</li> </ul>   |
|   | Unbalance                        | Considerable increase in coupling temperature. Premature wear of elastic buffers. Increased reaction forces act on connected machines  | <ul style="list-style-type: none"> <li>- Disconnect drive</li> <li>- Verify balance state of plant components and correct it, if necessary</li> <li>- Inspect elastic buffers for wear</li> </ul>  |
|   | Loose screw connections          | Flying parts can cause serious injuries and considerable damages.  | <ul style="list-style-type: none"> <li>- Disconnect drive</li> <li>- Check coupling parts for damages, replace parts, if necessary</li> <li>- Verify alignment of coupling</li> <li>- Tighten screws to the specified tightening torque and secure them against working loose, if necessary</li> <li>- Inspect elastic buffers for wear</li> </ul> |
| Premature wear of elastic buffers       | Alignment fault                  | Considerable increase in coupling temperature. Increased reaction forces act on connected machines.                                    | <ul style="list-style-type: none"> <li>- Disconnect drive</li> <li>- Remove cause for alignment fault</li> <li>- Re-align coupling</li> <li>- Inspect elastic buffers for wear</li> </ul>  |
|   | Unacceptable temperatures        | Material properties of elastic buffers change. The torque transmission capability is adversely affected.                               | <ul style="list-style-type: none"> <li>- Disconnect drive</li> <li>- Replace elastic buffers</li> <li>- Re-align coupling</li> <li>- Adjust ambient temperature</li> </ul>   |
|   | Contact with aggressive products | Material properties of elastic buffers change. The torque transmission capability is adversely affected.                               | <ul style="list-style-type: none"> <li>- Disconnect drive</li> <li>- Check coupling parts for damages and replace parts, if necessary</li> <li>- Replace elastic buffers</li> <li>- Verify alignment of coupling</li> <li>- Prevent contact with aggressive products</li> </ul>  |

| Trouble       | Cause   | Risk Warning   | Correction  |
|---------------|---|--|---|
|               | Torsional vibrations in the drive line                              | Considerable increase in coupling temperature. Premature wear of elastic buffers. Increased reaction forces act on connected machines. | <ul style="list-style-type: none"> <li>- Disconnect drive</li> <li>- Analyse and eliminate cause for torsional vibrations</li> <li>- Check coupling parts for damages and replace parts, if necessary</li> <li>- Replace elastomer element and consult TSCHAN GmbH concerning the use of another Shore-hardness</li> <li>- Verify coupling alignment</li> </ul> |
| Claw breakage | Wear limit of elastic buffers exceeded<br>====><br>contact of claws | Coupling is destroyed. Connected machines can also be affected.  | <ul style="list-style-type: none"> <li>- Disconnect drive</li> <li>- Replace coupling</li> <li>- Inspect the elastic buffers for wear at shorter intervals</li> </ul>   |
|               | Overload due to too high torque                                     | Coupling is destroyed. Connected machines ca also be affected.   | <ul style="list-style-type: none"> <li>- Disconnect drive</li> <li>- Verify coupling design in cooperation with TSCHAN GmbH</li> <li>- Replace coupling</li> <li>- Install larger coupling, if necessary</li> </ul>   |

## 9.1 Check of direction of rotation



- **Danger of injuries!**
- **Disconnect the drive before carrying out any work on the coupling!**
- **Secure the drive against unintentional re-start and rotation!**
- **Improperly tightened screws may cause parts to become flying projectiles and lead to most serious personal injuries and property damage!**
- **Before putting the coupling into operation, check the alignment and all screwed connections for correct tightening torque and firm fit!**
- **Before starting up the equipment, install all protective guards or covers in order to avoid contact with freely moving or rotating parts.**
- **To avoid sparks, covers made of stainless steel must be used!**
- **The covers have to comply with protection type IP2X as a minimum.**
- **The covers must be designed to prevent dust from depositing on the coupling parts.**
- **The covers must not touch the coupling nor impair its function.**



- **Attention!**
- **Checking the direction of rotation shall only be carried out while the coupling flange is still in place at the driving machine! Otherwise the risk of spark formation exists due to the retracted claw ring!**

- Remove the fastening screws at the claw ring and push it away from the buffer ring (Fig. 10, pos. 1).
- Secure the claw ring to prevent its displacement.
- Cut through the buffer ring at one of the connecting webs (Fig. 10, pos. 2).
- Pull out the buffer ring, starting from the cut incision on the web.

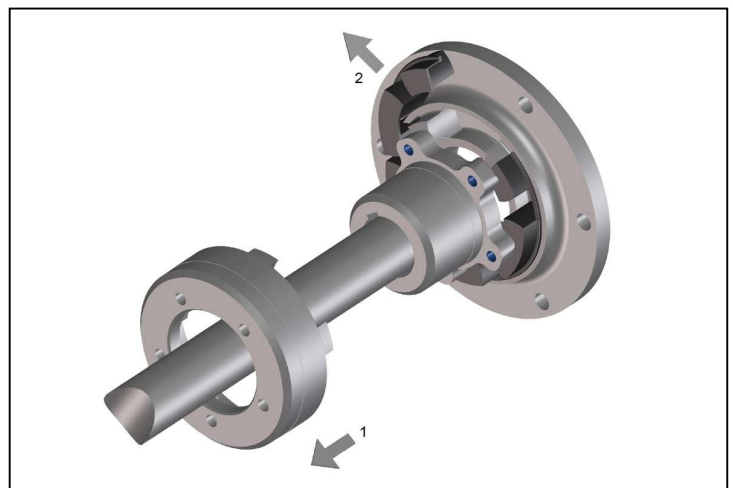

Fig. 10



- **Attention!**
- **Make sure that the coupling halves cannot move axially while checking the direction of rotation.**
- **The coupling half with the retracted claw ring must be stationary when checking the direction of rotation.**
- **The rotating half must not contact the stationary half!**



- After having checked the direction of rotation, cut through a new buffer ring at one of the connecting webs and insert it between the coupling hub and the flange.
- To facilitate mounting, the new buffer ring can be coated with a sliding substance (e.g. talcum).

**Attention!**

**The contact surfaces of the claw ring and flange hub must be clean, dry and free of grease. Balanced parts are match-marked to each other.**

- Insert the claw ring in the marked position relative to the hub. Pay attention that the parts do not get canted at the centering seat.
- Slightly tighten the screws in a uniform manner.
- Tighten the claw ring screws to the tightening torque  $M_A$  specified in table 9 (Fig. 11).
- Check the alignment of the coupling according to the instructions given in chapter 8 'Coupling Alignment'.

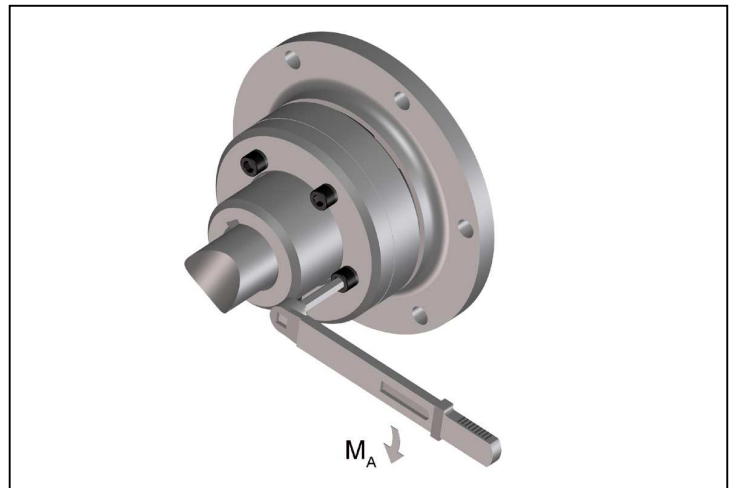

Fig. 11

**Table 9 Tightening torques  $M_A$  of the claw ring screws:**

|              |    |    |     |     |     |     |     |     |     |     |     |     |     |     |     |     |
|--------------|----|----|-----|-----|-----|-----|-----|-----|-----|-----|-----|-----|-----|-----|-----|-----|
| Size         | 82 | 97 | 112 | 128 | 148 | 168 | 194 | 214 | 240 | 265 | 295 | 330 | 370 | 415 | 480 | 575 |
| DIN 912- 8.8 | M6 | M6 | M8  | M8  | M10 | M10 | M10 |     |     |     |     |     |     |     |     |     |
| DIN 912-10.9 |    |    |     |     |     |     |     | M12 | M12 | M14 | M14 | M16 | M16 | M16 | M20 | M20 |
| $M_A$ [Nm]   | 10 | 10 | 25  | 25  | 49  | 49  | 49  | 125 | 125 | 200 | 200 | 310 | 310 | 310 | 610 | 610 |

## 10 Maintenance

The NOR-Mex<sup>®</sup>-LG, KG and MG couplings only require little maintenance. The time at which the wear limit of the elastic buffers is reached, depends on the service parameters and application conditions.

On the occasion of routine inspections or maintenance of the equipment, check:

- alignment of the coupling,
- state of the elastomer element,
- and remove dust deposits from coupling parts and buffers.

### 10.1 Wear inspection on the buffer ring



- **Danger of injuries!**
- **Disconnect the drive before carrying out any work on the coupling!**
- **Secure the drive against unintentional re-start and rotation!**

Perform a visual inspection and a wear inspection of the buffer ring after 2000 operation hours, or after 3 months at latest, after the first start-up of the equipment. If only minor wear or no wear is discovered, further inspections of the plant can be carried out at regular intervals of 4000 hours, but have to be performed at least once a year, if the operating modes and conditions of the plant remain unchanged. However, should excessive wear already be observed on the occasion of the first inspection, check whether the cause for the problem is listed in table 8 "Operation faults and possible causes". In such a case, the inspection intervals must be adapted to the prevailing service conditions.

On the occasion of routine inspections or maintenance work on the drive equipment, or after 3 years at latest:

- Replace the elastic buffer ring.
- If the wear limit has been reached or exceeded, replace the buffer ring immediately, irrespective of the inspection intervals of the equipment.
- Check the alignment of the coupling.
- Remove dust deposits from the coupling components and buffer ring.

## 10.2 Wear limit of the buffer ring

The buffer ring must be replaced immediately, if the coupling has a distinct circumferential backlash, or if the minimum buffer thickness ( $PD_{min}$ , Fig. 12) acc. to table 10 has been reached.

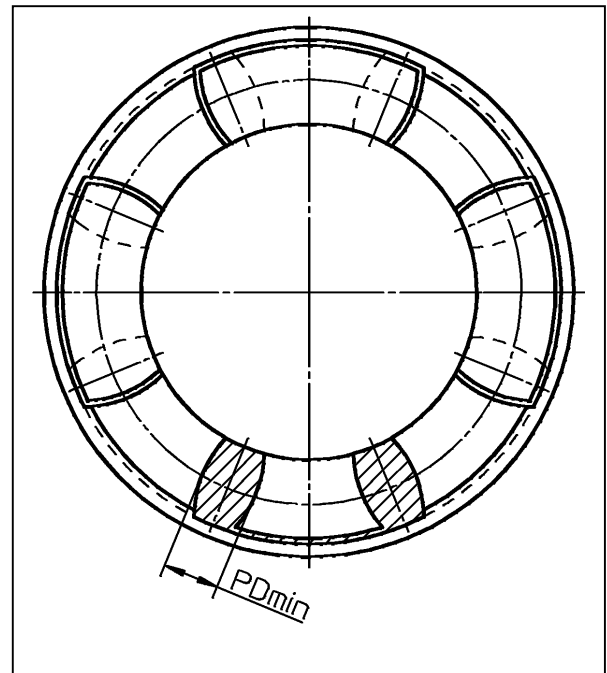

Fig. 12 Buffer thickness

Table 10 Minimum buffer thickness  $PD_{min}$ :

| Size            | 82 | 97 | 112 | 128 | 148 | 168 | 194 | 214 | 240 | 265 | 295 | 330 | 370 | 415 | 480 | 575 |
|-----------------|----|----|-----|-----|-----|-----|-----|-----|-----|-----|-----|-----|-----|-----|-----|-----|
| $PD_{min}$ [mm] | 8  | 9  | 9   | 9   | 10  | 10  | 10  | 10  | 11  | 12  | 13  | 14  | 16  | 17  | 17  | 17  |

## 10.3 Replacement of the buffer ring



- **Danger of injuries!**
- **Disconnect the drive before carrying out any work on the coupling!**
- **Secure the drive against unintentional re-start and rotation!**

- Remove the fastening screws at the claw ring and push it away from the buffer ring (Fig. 13, pos.1)
- Cut through the buffer ring at one of the connecting webs (Fig. 13, pos. 2).
- Pull out the buffer ring, starting from the cut incision on the web.
- To facilitate mounting, the new buffer ring can be coated with a sliding substance (e.g. talcum).
- Cut through a new buffer ring at one of the connecting webs and insert it between the coupling flange and the flange hub.

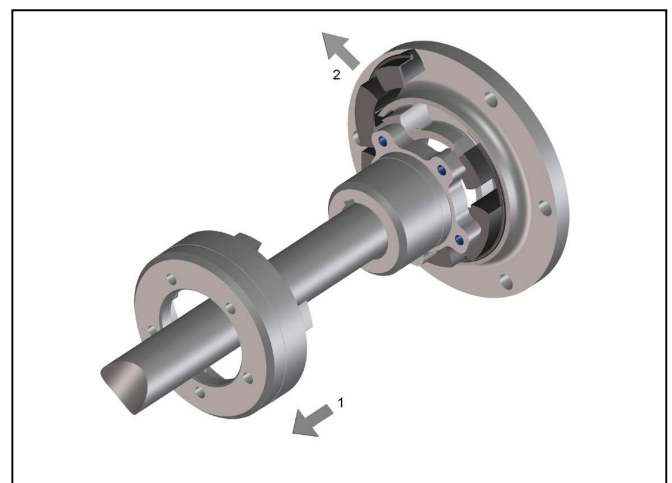

Fig. 13

**Attention!**

The contact surfaces of the claw ring and flange hub must be clean, dry and free of grease. Balanced parts are match-marked to each other.

- Insert the claw ring in the marked position. Pay attention that the parts do not get canted at the centering seat.
- Slightly tighten the screws in a uniform manner.
- Tighten the claw ring screws to the tightening torque  $M_A$  specified in table 11 (Fig. 14).
- Check the alignment of the coupling according to the instructions given in chapter 8 ‘Coupling Alignment‘.

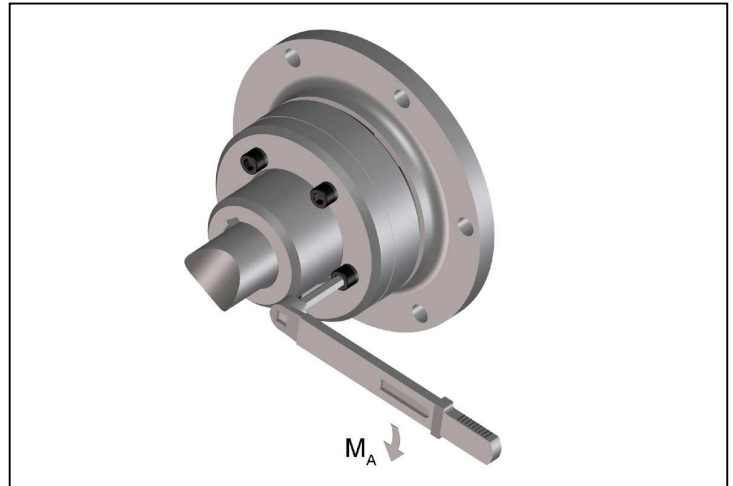

Fig. 14

**Table 11 Tightening torques  $M_A$  of the claw ring screws:**

|              |    |    |     |     |     |     |     |     |     |     |     |     |     |     |     |     |
|--------------|----|----|-----|-----|-----|-----|-----|-----|-----|-----|-----|-----|-----|-----|-----|-----|
| Size         | 82 | 97 | 112 | 128 | 148 | 168 | 194 | 214 | 240 | 265 | 295 | 330 | 370 | 415 | 480 | 575 |
| DIN 912- 8.8 | M6 | M6 | M8  | M8  | M10 | M10 | M10 |     |     |     |     |     |     |     |     |     |
| DIN 912-10.9 |    |    |     |     |     |     |     | M12 | M12 | M14 | M14 | M16 | M16 | M16 | M20 | M20 |
| $M_A$ [Nm]   | 10 | 10 | 25  | 25  | 49  | 49  | 49  | 125 | 125 | 200 | 200 | 310 | 310 | 310 | 610 | 610 |

**Warning!**



- Before starting up the equipment, install all the protective covers in order to avoid contact with freely moving or rotating parts.
- To avoid sparks, covers made of stainless steel must be used!
- The covers have to comply with protection type IP2X as a minimum.
- The covers must be designed to prevent dust from depositing on the coupling parts.
- The covers must not touch the coupling nor impair its function.

We do not assume any liability or warranty for any damages resulting from the use of accessories or parts which have not been originally manufactured by TSCHAN GmbH.

**11 Waste Disposal**

The waste disposal has to occur according to the specific regulations of the respective user country.